

NOTES:

1. INSTALLATION MUST COMPLY WITH NATIONAL AND LOCAL ELECTRICAL REGULATIONS.
2. PLEASE REFER TO THE PRODUCT MANUALS FOR DETAILED INFORMATION.
3. ALL DIMENSIONS ARE IN MILLIMETERS [INCHES].
4. NET WEIGHT OF UNIT IS 138.23 Kg [304.1 LBS].
5. CABLE ENTRY IS TOP OR BOTTOM OF UNIT.
6. FRONT AND REAR SERVICE ACCESS REQUIRED.
7. AIR FLOW AND SERVICE REQUIREMENTS, AS WELL AS MINIMUM CLEARANCE TO FIRE SUPPRESSION SYSTEMS SHOULD BE CONSIDERED WHEN LOCATING THE ENCLOSURE.

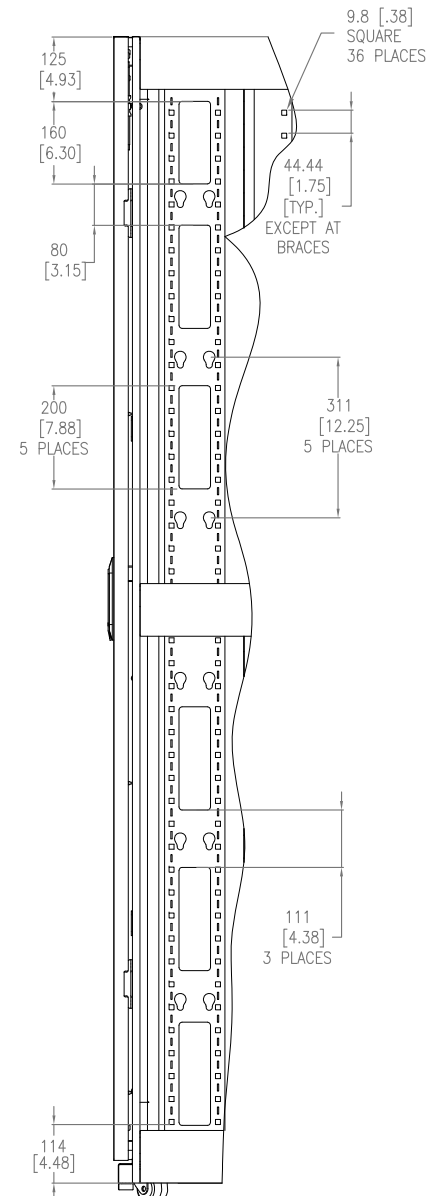

DETAIL-A
(RMPDU MOUNTING)

THIS DRAWING AND SPECIFICATIONS HEREIN ARE THE PROPERTY OF SCHNEIDER ELECTRIC AND SHALL NOT BE COPIED, REPRODUCED OR USED IN WHOLE OR IN PART, AS THE BASIS FOR THE MANUFACTURE OR SALE OF ITEMS WITHOUT WRITTEN PERMISSION FROM SCHNEIDER ELECTRIC. THIS DRAWING IS BASED UPON LATEST AVAILABLE INFORMATION AND IS SUBJECT TO CHANGE WITHOUT NOTICE.



TITLE: NetShelter SX 48U ENCLOSURE WITH SIDES 600mm WIDE x 1070mm DEEP MAIN MECHANICAL

DWG NO: AR3107

REV. 2

DRAWN BY: B ZAHN 16-JUL-09

FIRST ANGLE

ENGINEER: K THOMAS 16-JUL-09

PROJECTION

PROJECT: SUBMITTAL DRAWINGS SHEET 1 OF 3

APPROVED BY: SHERMAN/DICKSON/CURTIS'S INCH 16-JUL-09

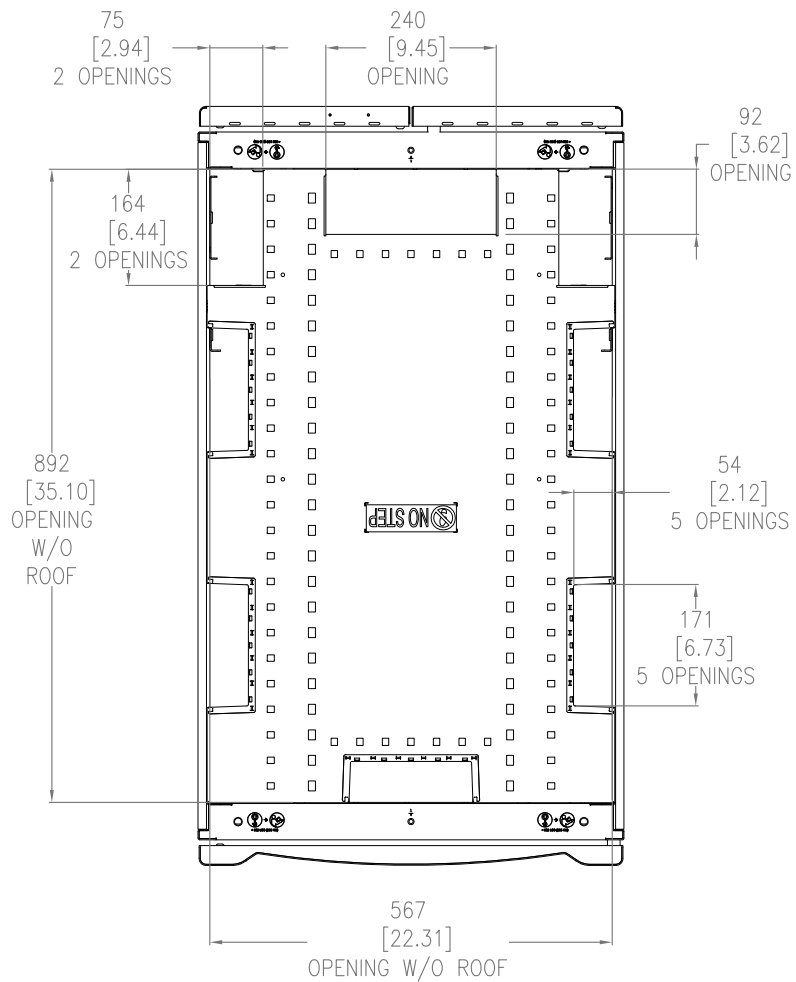

TOP VIEW
CABLE OPENINGS
(COVERS REMOVED)

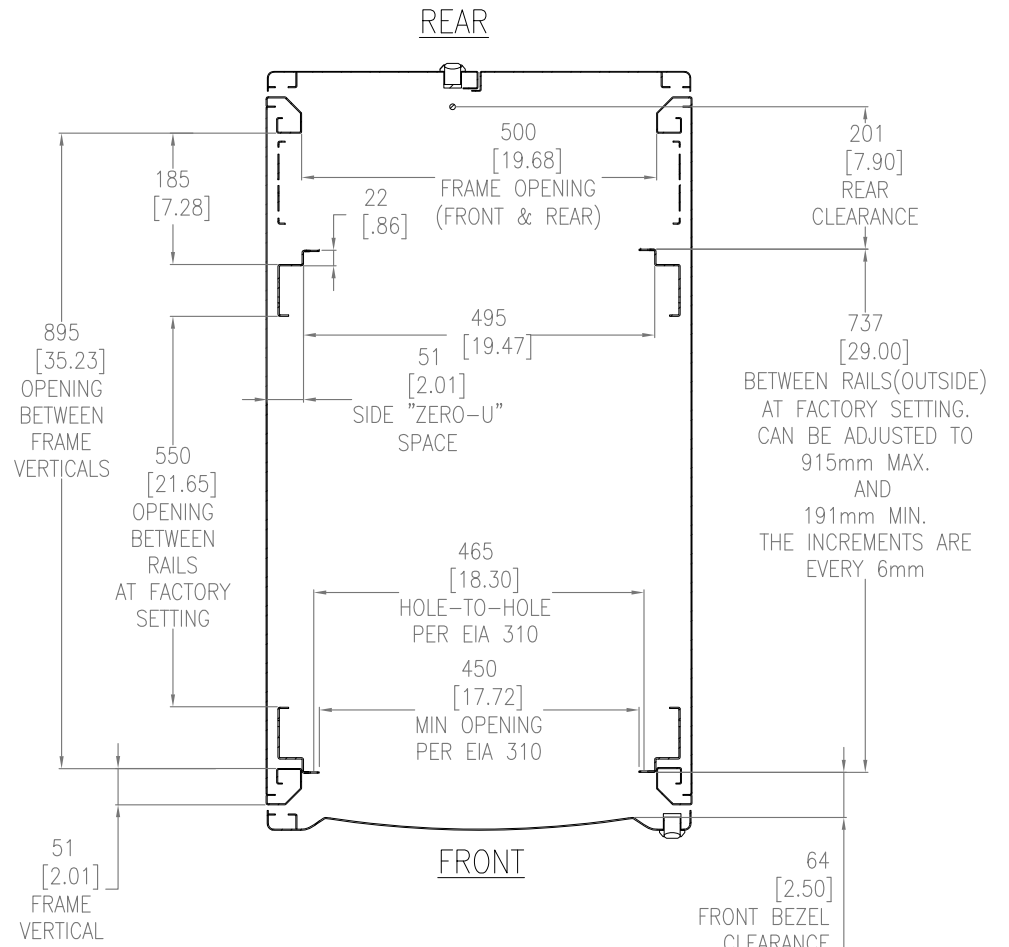

SECTION B-B
(VIEW FROM INSIDE CABINET,
LOOKING DOWN)

NOTES:

1. INSTALLATION MUST COMPLY WITH ALL APPLICABLE NATIONAL AND LOCAL CODES.
2. ALL DIMENSIONS ARE MILLIMETERS [INCHES].

THIS DRAWING AND SPECIFICATIONS HEREIN ARE THE PROPERTY OF SCHNEIDER ELECTRIC AND SHALL NOT BE COPIED, REPRODUCED OR USED IN WHOLE OR IN PART, AS THE BASIS FOR THE MANUFACTURE OR SALE OF ITEMS WITHOUT WRITTEN PERMISSION FROM SCHNEIDER ELECTRIC. THIS DRAWING IS BASED UPON LATEST AVAILABLE INFORMATION AND IS SUBJECT TO CHANGE WITHOUT NOTICE.



TITLE: NetShelter SX 42U
ENCLOSURE WITH SIDES
600mm WIDE x 1070mm DEEP
TOP VIEWS

DWG NO: AR3107

REV. 3

DRAWN BY: B ZAHN 16-JUL-09

FIRST ANGLE

ENGINEER: K THOMAS 16-JUL-09

PROJECTION

PROJECT: SUBMITTAL DRAWINGS SHEET 2 OF 3

APPROVED BY: G SHERRIFF / MESA / C LARSON'S INCH 16-JUL-09

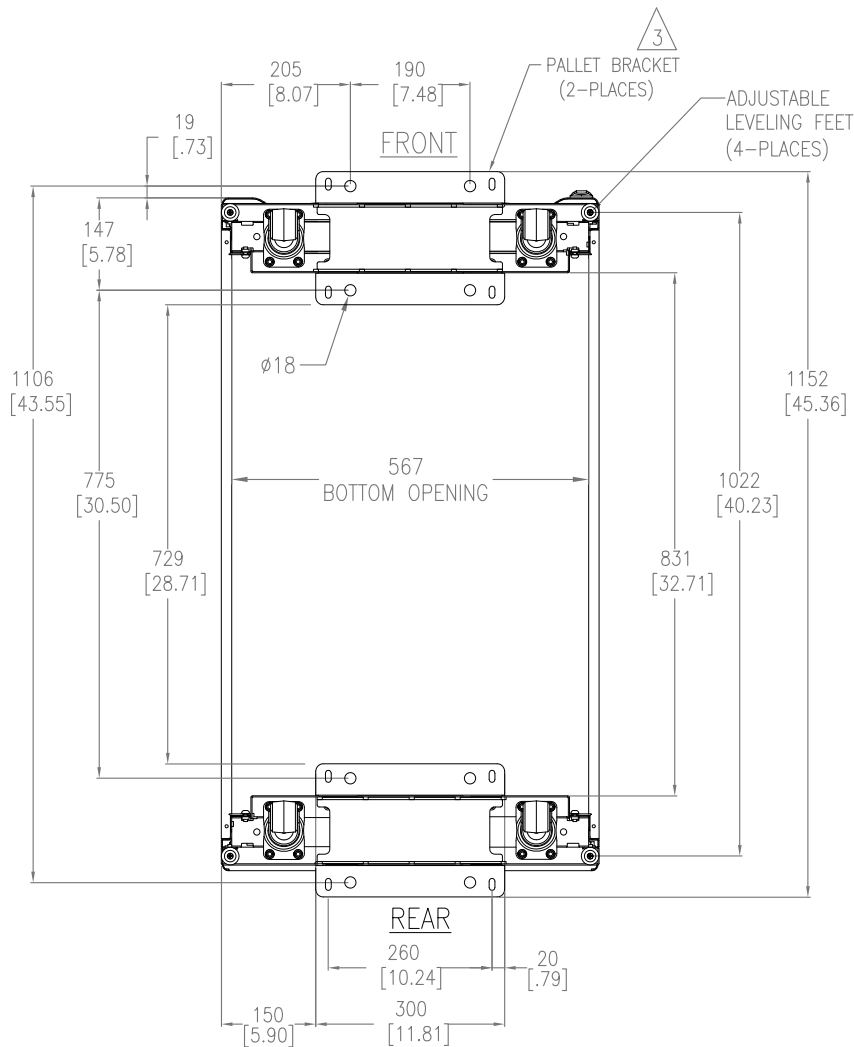

**BOTTOM VIEW
WITH PALLET BRACKETS**
(CAN BE USED FOR ANCHORING)

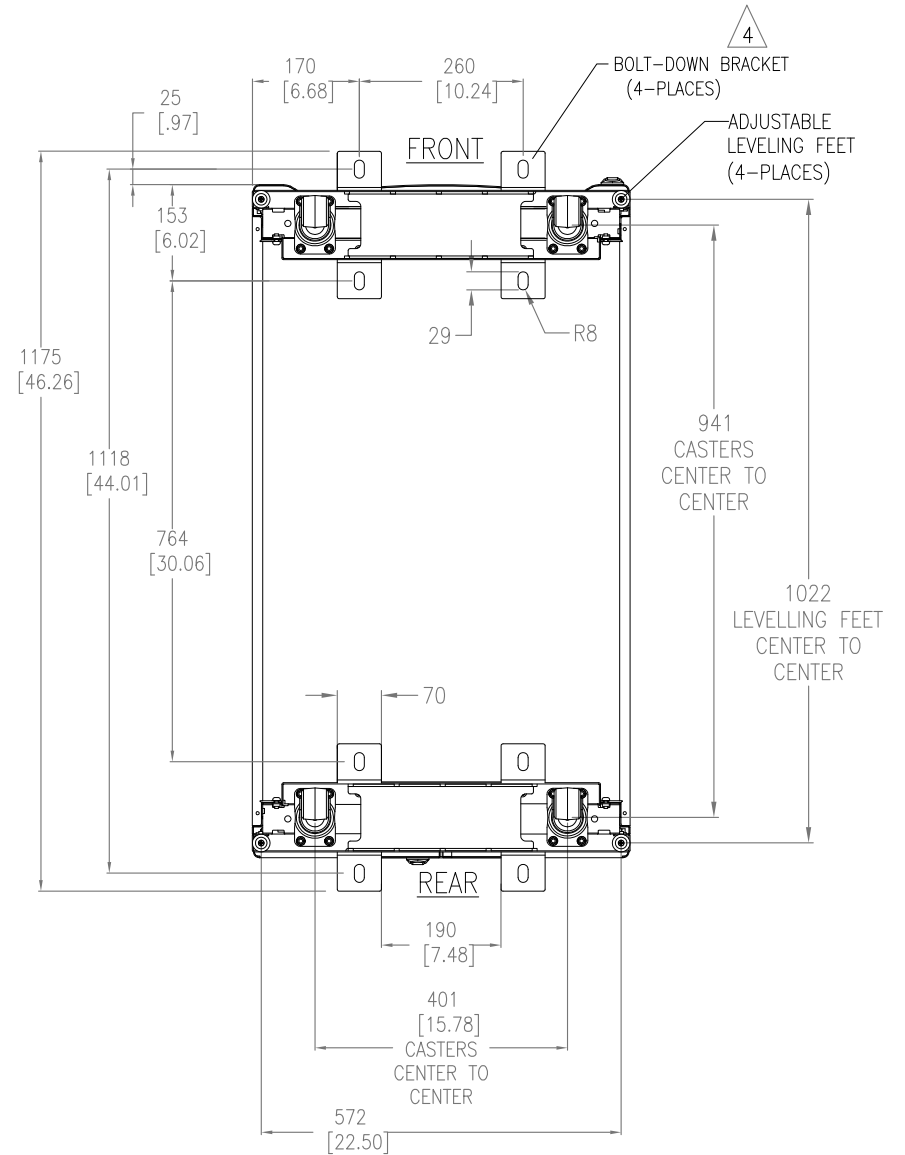

BOTTOM VIEW
(WITH OPTIONAL BOLT-DOWN BRACKETS
FOR ANCHORING)

NOTES:

1. INSTALLATION MUST COMPLY WITH ALL APPLICABLE NATIONAL AND LOCAL CODES.
2. ALL DIMENSIONS ARE MILLIMETERS [INCHES].
- △3. ANCHORING CAN BE INSTALLED EITHER INSIDE OR OUTSIDE THE NetShelter WITH ONE AT FRONT AND ONE IN BACK.
- △4. BOLT-DOWN KIT (SKU# AR7701) IS OPTIONAL AND HAS TO BE ORDERED SEPARATELY.

THIS DRAWING AND SPECIFICATIONS HEREIN ARE THE PROPERTY OF SCHNEIDER ELECTRIC AND SHALL NOT BE COPIED, REPRODUCED OR USED IN WHOLE OR IN PART, AS THE BASIS FOR THE MANUFACTURE OR SALE OF ITEMS WITHOUT WRITTEN PERMISSION FROM SCHNEIDER ELECTRIC. THIS DRAWING IS BASED UPON LATEST AVAILABLE INFORMATION AND IS SUBJECT TO CHANGE WITHOUT NOTICE.

**Schneider
Electric**

TITLE: NetShelter SX 42U
ENCLOSURE WITH SIDES
600mm WIDE x 1070mm DEEP
BOTTOM VIEWS

DWG NO: AR3107

REV. 3

DRAWN BY: B ZAHN 16-JUL-09

FIRST

ENGINEER: K THOMAS 16-JUL-09

ANGLE

PROJECT: SUBMITTAL DRAWINGS | SHEET 3 OF 3

APPROVED BY: SHERIDAN / DUSA / C LARSON'S INCH 16-JUL-09

PROJECTION